

PARTS MANAGER SPECIAL

CREATED 8/24

WHILE SUPPLIES LAST

EX-GUARD[®] PRESEASON BLOWOUT

Introducing our new B2B ECOMMERCE SOLUTION
SHOP.BERGEYSTRUCK.COM

EASY. FAST. ACCURATE.

CREATE YOUR
ACCOUNT TODAY!



XG-125G2

Extreme-duty, mid-height protection for the bumper, fog lights, radiator, and CMS on set-back axle truck models. Generation 2 design, with sharper bends, curves back towards the truck for increased aerodynamics, resulting in additional fuel efficiency.

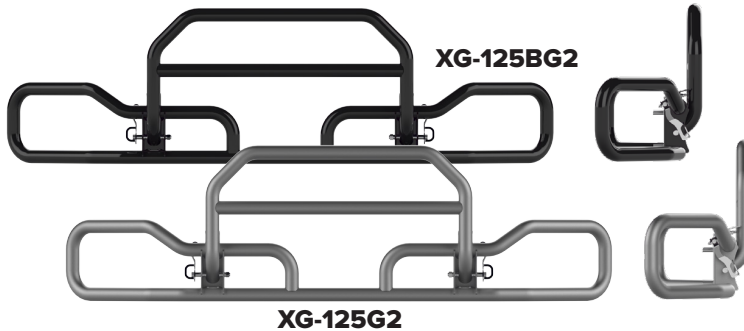

XG-125G2

XG-125BG2

FINISH: Ex-Guard[®] Corrosion Resistant PVC coating
MATERIAL: 8-Gauge High-Tensile Steel
LATCH TYPE: Adjustable, Dual-Action
COMPATIBILITY: Set-Back Axle Models
GUARD CONSTRUCTION: 2-piece
WEIGHT: 135 lbs
DIMENSIONS: 94" W x 27" H

\$1,189.99_{ea}

XG-125G2 SILVER
XG-125BG2 BLACK

XG-150G2

Extreme-duty, complete front-end protection for the bumper, fog lights, radiator, CMS, headlights, hood and grille for set-back axle truck models. Generation 2 design, with sharper bends, curves back towards the truck for increased aerodynamics, resulting in additional fuel efficiency.

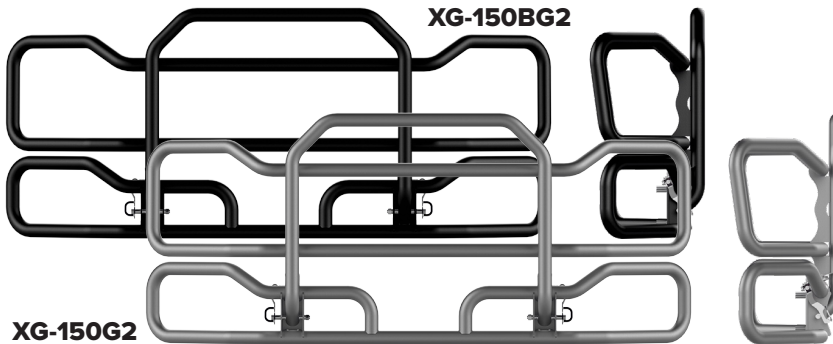

XG-150G2

XG-150BG2

FINISH: Ex-Guard[®] Corrosion Resistant PVC coating
MATERIAL: 8-Gauge High-Tensile Steel
LATCH TYPE: Adjustable, Dual-Action
COMPATIBILITY: Set-Back Axle Models
GUARD CONSTRUCTION: 2-piece
WEIGHT: 135 lbs
DIMENSIONS: 94" W x 40" H

\$1,540.99_{ea}

XG-150G2 SILVER
XG-150BG2 BLACK

XG-D175G2

Extreme-duty, complete front-end protection for the bumper, fog lights, radiator, CMS, headlights, grille and maximum hood coverage for select set-back axle truck models. Generation 2 design, with sharper bends, curves back towards the truck for increased aerodynamics, resulting in additional fuel efficiency.

DEEP STYLE - Recommended for Mack Anthem (plastic bumper) models only.

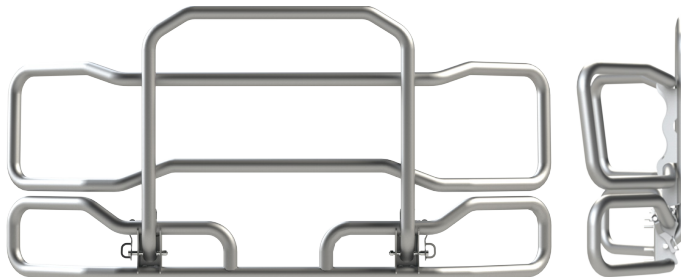

XG-D175G2

FINISH: Ex-Guard[®] Corrosion Resistant PVC coating
MATERIAL: 8-Gauge High-Tensile Steel
LATCH TYPE: Adjustable, Dual-Action
COMPATIBILITY: Mack Anthem (plastic bumper)
GUARD CONSTRUCTION: 2-piece
WEIGHT: 240 lbs (not including brackets)
DIMENSIONS: 94" W x 50" H

\$1,763.99_{ea}

XG-D175G2 SILVER

LT-325G2

A lightweight, mid-height solution. Protection for the bumper, fog lights, radiator, and CMS for set-back axle truck models. Generation 2 design, with sharper bends, curves back towards the truck for increased aerodynamics, resulting in additional fuel efficiency. The LT 300 series utilize a lighter, high strength 11 gauge steel, corrosion resistant and maintenance free PVC coating. The lighter steel results in a 25% reduction in weight.



\$763.99_{ea}

LT-325G2 SILVER
LT-325BG2 BLACK

XG-D100BG2

Extreme-duty, lower protection for the bumper and fog lights on set-back axle truck models. Generation 2 design, with sharper bends, curves back towards the truck for increased aerodynamics, resulting in additional fuel efficiency.

DEEP STYLE - Recommended for Mack Anthem, Freightliner New Generation (P4) Cascadia & Western Star 57X models only.



\$816.99_{ea}

XG-D100BG2 BLACK

XG-D125G2

Extreme-duty, mid-height protection for the bumper, fog lights, radiator, and CMS on set-back axle truck models. Generation 2 design, with sharper bends, curves back towards the truck for increased aerodynamics.

DEEP STYLE - Recommended for Mack Anthem, Freightliner New Generation (P4) Cascadia & Western Star 57X models only.

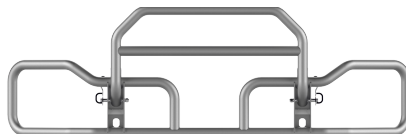

\$1,210.99_{ea}

XG-D125G2 SILVER

XG-D150BG2

Extreme-duty, complete front-end protection for the bumper, fog lights, radiator, CMS, headlights, hood and grille for set-back axle truck models. Generation 2 design, with sharper bends, curves back towards the truck for increased aerodynamics, resulting in additional fuel efficiency.

DEEP STYLE - Recommended for Mack Anthem (steel bumper), Freightliner New Generation (P4) Cascadia & Western Star 57X models only.



\$1,729.99_{ea}

XG-D150BG2 BLACK

SEE REVERSE FOR BRACKET KITS TO COMPLETE YOUR INSTALL!



OVER 26 LOCATIONS TO BETTER SERVE YOU

BergeysTruckCenters.com | BergeysTruckParts.com | Shop.BergeysTruck.com



MOUNTING BRACKET KITS

XG-22VNL

This kit includes the following:

- (1) Driver side bracket
- (1) Passenger side bracket
- (1) Complete hardware kit

This bracket kit fits:
Volvo VNL, 2017 - 2024
Volvo VNM, 2017 - Later

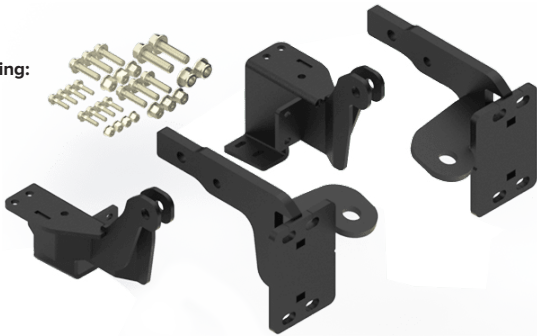

\$461.50_{ea}

XG-22VNL



XG-18VNR

This kit includes the following:

- (1) Driver side bracket
- (1) Passenger side bracket
- (1) Complete hardware kit

This bracket kit fits:
Volvo VNR, 2018 - Later



\$461.50_{ea}

XG-18VNR

XG-04MH

This kit includes the following:

- (1) Driver side bracket
- (1) Passenger side bracket
- (1) Complete hardware kit

This bracket kit fits:
Mack Pinnacle (set-forward)
Mack CH (set-forward), 2004 - Later



\$461.50_{ea}

XG-04MH

XG-18MA

This kit includes the following:

- (1) Driver side bracket
- (1) Passenger side bracket
- (1) Complete hardware kit

This bracket kit fits:
Mack Anthem (steel bumper)
*** for plastic bumper use XG-18DMA*



\$461.50_{ea}

XG-18MA

XG-18KP

This kit includes the following:

- (1) Driver side bracket
- (1) Passenger side bracket
- (1) Complete hardware kit

This bracket kit fits:
Kenworth T680 (old style), 2012 - 2021
Kenworth T700, 2010 - Later
Peterbilt 384 (set-back)
Peterbilt 579 (old style), 2012 - 2021
Peterbilt 587, 2011 - Later



\$461.50_{ea}

XG-18KP

XG-18DMA

This kit includes the following:

- (1) Driver side bracket
- (1) Passenger side bracket
- (1) Complete hardware kit

This bracket kit fits:
Mack Anthem (plastic bumper)
*** for steel bumper use XG-18MA*

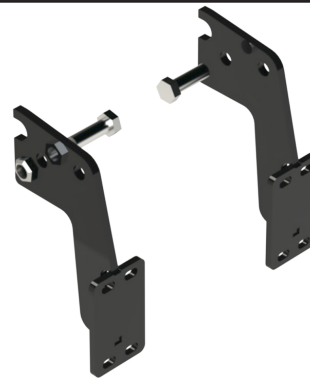

\$461.50_{ea}

XG-18DMA



XG-20FNCA

This kit includes the following:

- (1) Driver side bracket
- (1) Passenger side bracket
- (1) Complete hardware kit

This bracket kit fits:
Freightliner Cascadia New Gen. (with mold in bumper)



\$461.50_{ea}

XG-20FNCA



XG-20FNCAE

This kit includes the following:

- (1) Driver side bracket
- (1) Passenger side bracket
- (1) Complete hardware kit

This bracket kit fits:
Freightliner Cascadia (w/upper tow hooks), 2008 - 2017
Freightliner Century Class, 2008 - 2010
Freightliner Columbia, 2008 - 2011
Freightliner Cascadia New Gen. (with Aero Clad® steel bumper)



\$461.50_{ea}

XG-20FNCAE

XG-13FCAHP

This kit includes the following:

- (1) Driver side bracket
- (1) Passenger side bracket
- (1) Complete hardware kit

This bracket kit fits:
Western Star (lower tow hooks)
Freightliner Cascadia (lower tow hooks), 2008 - 2018

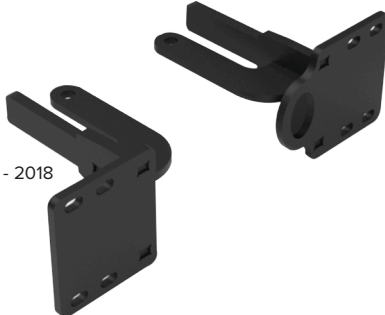

\$461.50_{ea}

XG-13FCAHP

XG-LP10

This kit includes the following:

- (1) License plate bracket
- (1) Complete hardware kit

This bracket kit fits
all Ex-Guard products.



\$81.99_{ea}

XG-LP10



OVER 26 LOCATIONS TO BETTER SERVE YOU

BergeysTruckCenters.com | BergeysTruckParts.com | Shop.BergeysTruck.com

